

## Steel Conic Litter bin

Ref.MUP001

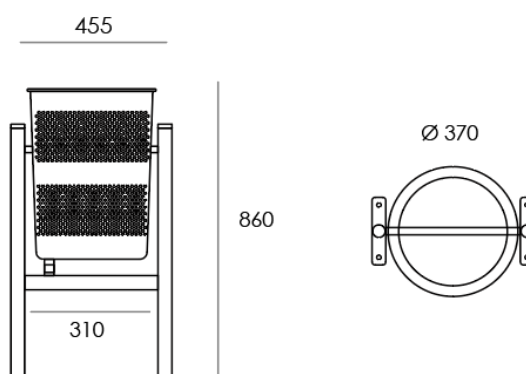

### Specifications

- Metal frame litterbin in perforated and painted steel.
- Body in galvanized steel.
- Epoxy primer and polyester paint, baked grey enamel.
- Attach to the base for proper fixation to the ground.
- Reinforced legs for better support.
- Folding bucket for easy emptying.
- Capacity 60 liters.