

## Purple Conic Litter bin

Ref.MUP001

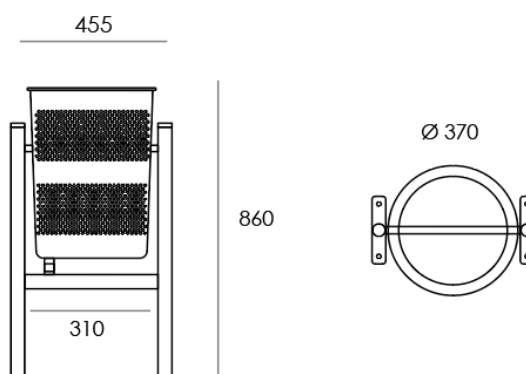

### Specifications

- Litter bin with metallic structure in perforated and painted steel.
- Body in galvanized steel.
- Epoxy primer and purple baked polyester paint.
- Anchorage to the base for its correct fixing to the ground.
- Reinforced legs for better support.
- Folding bucket for easy emptying.
- Capacity 60 liters.